



CONTENTS

(Click on a topic to view)

[Congratulations](#)

[Ported Enclosure](#)

[PC PRO15 Specifications](#)

[Bandpass Enclosure](#)

[Introduction](#)

[Bandpass Enclosure](#)

[Speaker Cutaway](#)

[PC PRO15 Dimensions](#)

[Sealed Enclosure](#)

[PC PRO15 Response Graphs](#)

[Sealed Enclosure](#)

[Additional Information](#)

[Ported Enclosure](#)

[Warranty](#)

Congratulations and thank you.....

for choosing *PrecisionPower* audio equipment. At *PrecisionPower* we proudly design, engineer and manufacture audio products at our facility in Phoenix, Arizona. Our award winning engineering team utilizes innovative technology to consistently deliver Absolutely State of the Art™ performance, sound quality, reliability, and value. This *PrecisionPower* product reflects our commitment to offer you unparalleled versatility and quality for years of dependable service and listening enjoyment.

Service



Do not attempt to service *PrecisionPower* products yourself. Performing exploratory surgery on your audio equipment yourself will void the warranty. Many parts of your *PrecisionPower* gear are custom built to our specifications. Our factory parts are not made available to anyone else nor are they for sale. Our goal is to make sure that your *PrecisionPower* product will always sound as good as the day it was purchased. Contact your authorized *PrecisionPower* dealer about obtaining any warranty service through *PrecisionPower*. (See Warranty inside back cover)

FOR YOUR RECORDS:

M o d e l _____

Serial Number _____

Purchase Date _____

Caution!



The extended use of a high powered audio system may result in hearing loss or damage. While *PrecisionPower* systems are capable of "Concert Level" volumes with incredible accuracy, they are also designed for you to enjoy at more reasonable levels all of the sonic subtleties created by musicians. Please observe all local sound ordinances.

[RETURN TO CONTENTS](#)

POWERCLASS PRO15 Subwoofer

PRO15 Specifications

Normal Power Handling	600W rms
Voice Coil Diameter	5"
Voice Coil Type / Former	Edge wound/Aluminum
Resonant Frequency	31Hz
Qts-Total Damping	0.34
Qms- Mechanical Damping	1.21
Qes- Electromagnetic Damping	0.47
Vas- Equivalent Compliance Volume	108.43 Liter
DC Resistance of V.C.	4Ω / 8Ω
Sensitivity (SPL at 1W)	90.51 dB
Linear Excursion	±6.25mm
Peak to Peak Excursion	31.5mm
Mms- Total Mass	207.04grams
Sd- Piston Area	0.0790 sqM
Bl- Magnet Product	18.73 TM
Diaphragm Material	Carbon fiber/Nomex honeycomb
Basket Material	Cast Aluminum
Net Weight	41 lb
Dimensions	15.143" dia. X 5.63" H
Mounting Hole Diameter	13.75" dia.
Mounting Depth	5.00"
Displacement	.21 cubic feet

PRO15 Enclosure Recommendations

SPL 1:	3.0 cu.ft. Bandpass 1.0 Sealed/2.0 Ported, 2) 4"Dia x 2.5"L Ports	F3: 55Hz
SPL 2:	2.0 cu.ft. Ported 1) 6"Dia x 12.75"L Port	F3: 38Hz
General Use 1:	2.0 cu.ft. Ported 1) 6"Dia x 12.75"L Port	F3: 38Hz
General Use 2:	1.75 cu.ft. Ported 1) 4"Dia x 6.125"L Port	F3: 40Hz
Audiophile 1:	1.5 cu.ft. Ported 1) 4"Dia x 7.75"L Port	F3: 42Hz
Audiophile 2:	1.5 cu.ft. Sealed	F3: 44Hz

See page 10 for examples of dimensions for these enclosures.

INTRODUCTION

Your new **PowerClass PRO15** Flat Piston subwoofer is part of an exciting line of loudspeakers which represent the extraordinary design achievements of the **PrecisionPower** Engineering Team.

The **PrecisionPower, PowerClass PRO** Flat Piston subwoofers have been engineered from the ground up and are constructed at our factory in Phoenix from the finest materials available. Like all **PrecisionPower** products, they reflect our commitment to “*Absolutely State of the Art*” performance and flawless sonic quality.

The **PRO15** subwoofers incorporate a 5” voice coil, edge wound onto a Black Anodized Aluminum former, and are available in 4Ω and 8Ω versions. The voice coils are cooled and given increased mechanical damping through the use of a ferrofluid filled magnetic gap. The cooling, and therefore power handling, is further enhanced by virtue of the inverted coil geometry, together with vented pole piece, spiders, and magnet cavity. The use of an inverted coil geometry results in a substantial reduction of distortion over conventional loudspeaker topology. Increased linearity over a large excursion is obtained by using dual matched rear suspension components together with the finest quality rubber roll surround.

The most unique feature is the use of a flat diaphragm instead of a conical structure. The diaphragm consists of a Nomex Honeycomb substrate between two Carbon Fiber skins. The result is a diaphragm that is exceptionally stiff and lightweight which does not exhibit cone flex distortion or the buckling effects inherent in conventional designs. Additionally, **PrecisionPower's** exclusive basket design is extremely rigid which ultimately removes any unwanted distortion due to resonance and flexing.

Included in this manual are a number of sample enclosure drawings. They are by no means the only enclosures to use, but rather a starting point in the right direction. To determine the correct enclosure for your needs many factors need to be addressed (amount of power, vehicle, placement, crossover, etc.) Therefore, as always, **PrecisionPower** recommends that your subwoofer be installed by an *Authorized PrecisionPower Dealer*.

SPEAKER CUTAWAY

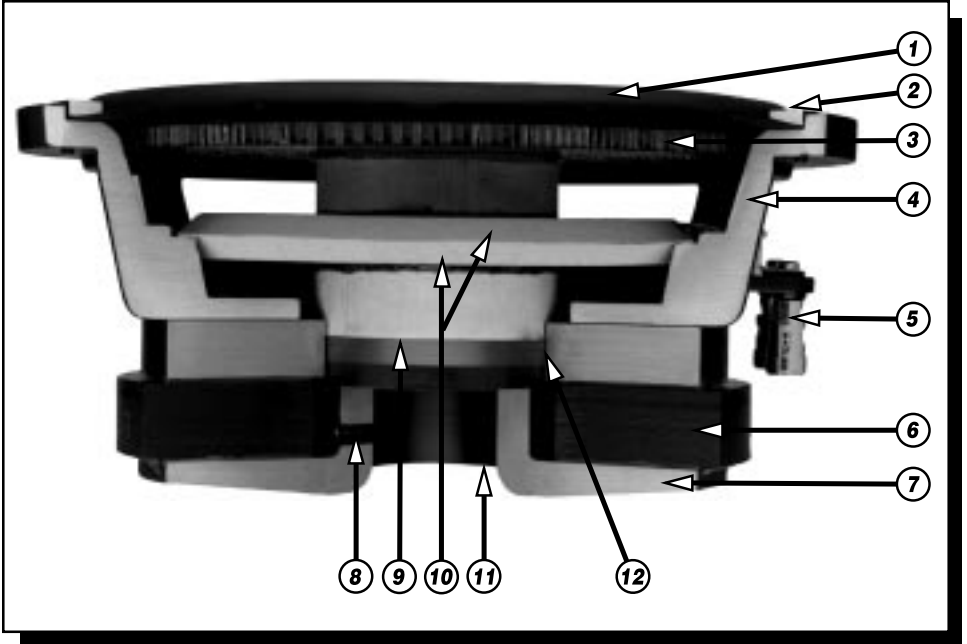

1. Rubber roll surround
2. Aluminum trim ring
3. Carbon fiber/Nomex honeycomb diaphragm
4. Cast aluminum basket
5. Gold plated, heavy duty terminal posts
6. Magnet structure
7. Forged steel back plate
8. Magnet cavity vent
9. Edge wound voice coil/
black anodized aluminum former
10. Dual spiders
11. Vented pole piece
12. Ferrofluid filled magnetic gap

SEALED ENCLOSURE

Building A Sealed Enclosure:

1. Build a sealed enclosure with internal L x W x D as specified for your woofer (See page 10). Use 1" thick MDF (medium density fiber board) for the baffle that the Subwoofer mounts in, and 3/4" thick MDF for the rest of the enclosure. Be sure to use wood glue and silicone to ensure your enclosure is sealed properly, as air leaks will affect the performance of your subwoofer.
2. Using the supplied template, trace the appropriate circle and mounting hole pattern for your *PrecisionPower* subwoofer on the baffle board. (See diagram)
3. Cut the speaker hole from the baffle board with a router. Use a guide or template whenever possible for a clean, accurate job; use a jig saw only if a router is not available. Drill out the holes for the T-nuts with a 7/32" drill bit.
4. Place the woofer in the opening which you have cut in the baffle to check the fit. Make sure that the T-nut holes line-up.
5. Install the 10-32 T-nuts (supplied) into the 7/32" holes from the backside of the baffle board.
6. Run an appropriate length of wire into the enclosure, leaving enough length to comfortably install the wires to the terminals on the woofer before placing the speaker into its mounting hole. Use a terminal cup whenever possible.
7. Vacuum out any wood shavings and dust from the inside of the enclosure. (Failure to do so may void your warranty.) Loosely fill the box half way with polyester fiberfill.
8. Apply the included foam gasket to the speaker to ensure a sealed fit. Be sure that the mounting holes line up on the foam gasket.
9. Connect the wires to the woofer observing the proper polarity, positive and negative terminals. Strip away the insulation of the wire about 1/4" and install the wires into the terminal posts.
10. Install the woofer into the enclosure using the 10-32 bolts (supplied).
11. Once the enclosure is complete, it is time to connect the speaker wire coming from the subwoofer enclosure to your amplifier. Check that you use the proper wire for consistent polarity, positive and negative. (Refer to amplifier owner's manual.)
12. Finally, sit back and enjoy the incredible enhancement your new *PrecisionPower* subwoofer brings to your audio system.

SEALED ENCLOSURE

Sealed speaker diagram

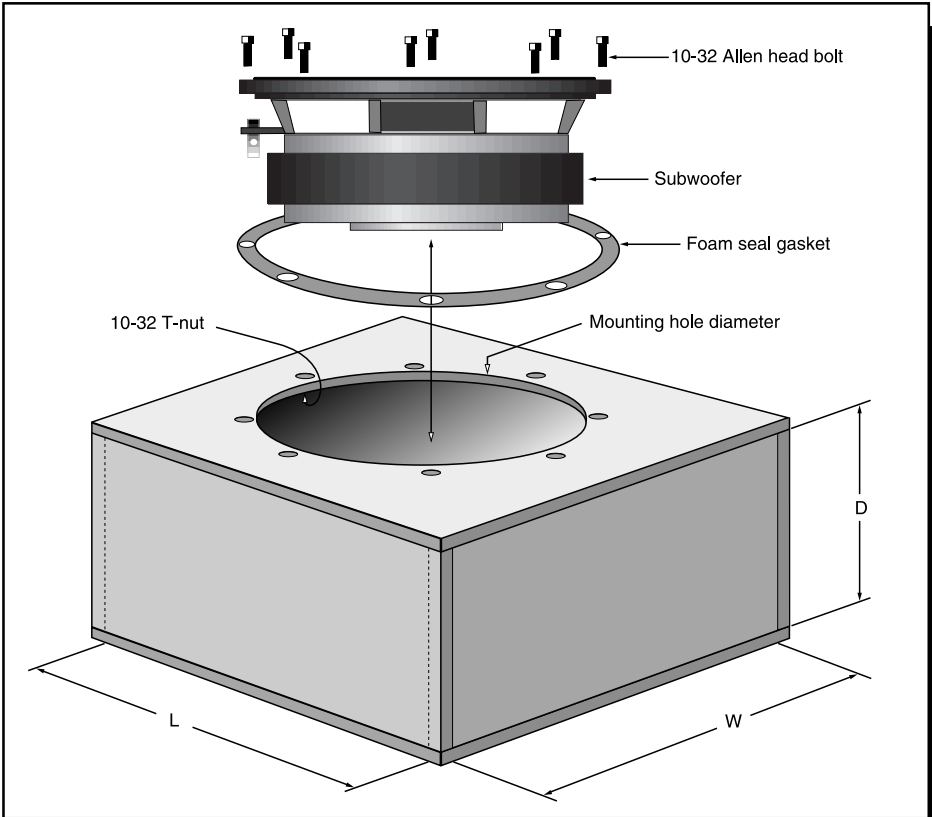

Internal dimensions should be calculated to determine the correct box volume.
Be sure to allow for speaker displacement and extra bracing (if used).

PORTED ENCLOSURE

Building A Ported Enclosure:

1. Build a ported enclosure with internal dimensions of LxWxD as specified for your woofer (See page 10). Use 1" thick MDF (medium density fiber board) for the baffle that the Subwoofer mounts in, and 3/4" thick MDF for the rest of the enclosure. Be sure to use wood glue and silicone to ensure your enclosure is sealed properly, as air leaks will affect the performance of your subwoofer.
2. Using the supplied template, trace the appropriate circle and mounting hole pattern for your *PrecisionPower* subwoofer on the baffle board. Be sure to offset the woofer to one side to leave room for the port in the baffle. (See Diagram)
3. Cut the speaker hole out of the baffle board with a router. Use a guide or template whenever possible for a clean, accurate job; use a jig saw only if a router is not available. Drill out the mounting holes for T-nuts with a 7/32" drill bit.
4. Locate the port material which you are going to use. Trace the pattern of the appropriate hole needed for the port, then cut the hole out. When installing the port, make sure you have a distance of at least one port diameter from the end of the port to the wall inside the box. Also, round over the inside edge of both ends of the port to cut down on port noise.
5. Place the woofer into the hole which you have cut in the baffle to check the fit. Make sure that the T-nut holes line up.
6. Install the 10-32 T-nuts (supplied) into the 7/32" holes from the backside of the mounting board.
7. Run an appropriate length of wire into the box, leaving enough to comfortably install the wires to the terminals on the woofer before placing the speaker into its mounting hole. Use a terminal cup whenever possible.
8. Vacuum out any wood shavings and dust from the inside of the enclosure. (Failure to do so may void your warranty.) Line the enclosure with a polyester fiberfill blanket or fiberglass insulation about 1" thick.
9. Apply the included foam gasket to the speaker to ensure a sealed fit. Be sure that the mounting holes line up on the gasket.
10. Connect the wires to the woofer observing the proper polarity, positive and negative terminals. Strip away the insulation of the wire about a 1/4" and install the wires into the terminal posts.
11. Install the woofer into the box using the 10-32 bolts (supplied).
12. Once the box is complete, it's time to connect the speaker wire coming from the subwoofer enclosure to your amplifier. Check that you use the proper wire for consistent polarity, positive and negative. (Refer to amplifier owner's manual.)
13. Finally, sit back and enjoy the incredible enhancement your new *PrecisionPower* subwoofer brings to your audio system.

PORTED ENCLOSURE

Ported speaker diagram

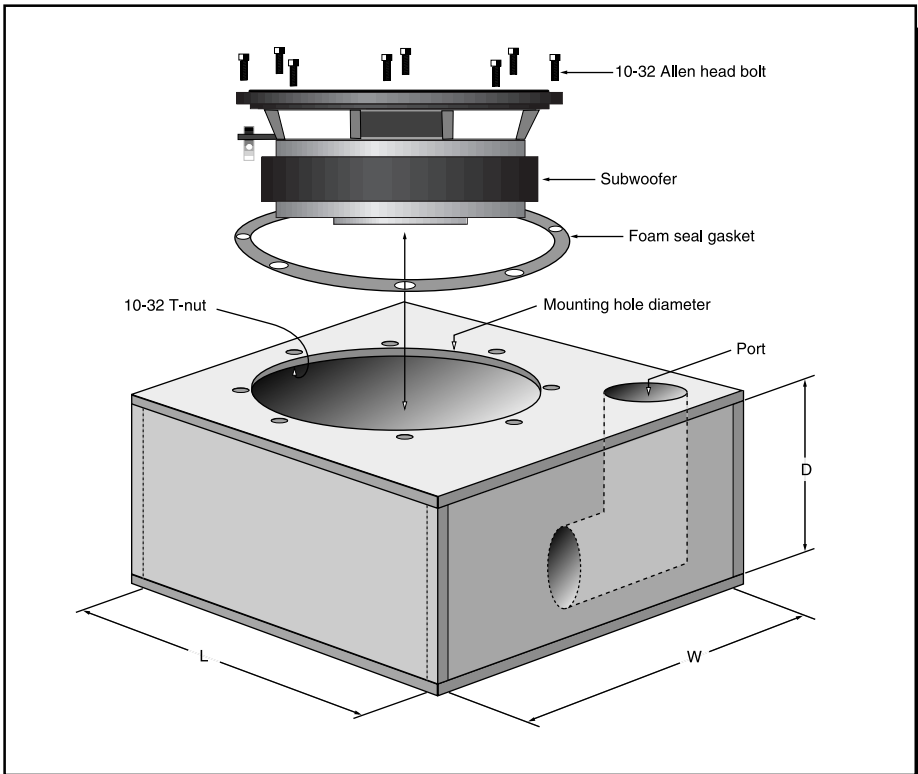

Internal dimensions should be calculated to determine the correct enclosure volume. Be sure to allow for speaker displacement, extra bracing (if used), and port displacement (only the length of the port that is INSIDE the enclosure). It may be necessary to angle the port to fit your design. To calculate the displacement of the port:
(Outside) $\text{Radius}^2 \times 3.14 \times \text{Length of the port that is inside the enclosure.}$

BANDPASS ENCLOSURE

Building A Bandpass Enclosure:

1. Build a divided enclosure with internal dimensions of LxWxC1 and C2 as specified for your woofer (See page 10). Use 1" thick MDF (medium density fiber board) for the baffle that the Subwoofer mounts in, and 3/4" thick MDF for the rest of the enclosure. Be sure to use wood glue and silicone to ensure your enclosure is sealed properly, as air leaks will affect the performance of your subwoofer.
2. Using the supplied template, trace the appropriate circle and mounting hole pattern for your *PrecisionPower* subwoofer on the baffle board.
3. Cut the speaker hole out of the baffle with a router. Use a guide or template whenever possible for a clean, accurate job; use a jig saw only if a router is not available. Drill out the mounting holes for T-nuts with a 7/32" drill bit.
4. Locate the port material which you are going to use. Trace the pattern of the appropriate hole needed for the port, then cut the hole out. When installing the port, make sure you have a distance of at least one port diameter from the end of the port to the inside wall of the enclosure. Also, round over the inside edge of both ends of the port to cut down on port noise.
5. Place the woofer into the hole which you have cut in the baffle to check the fit. Make sure that the T-nut holes line up.
6. Install the 10-32 T-nuts (supplied) into the 7/32" holes from the backside of the baffle board.
7. Run an appropriate length of wire into the enclosure, leaving enough to comfortably install the wires to the terminals on the woofer before placing the speaker into its mounting hole. Use a terminal cup whenever possible.
8. Vacuum out any wood shavings and dust from the inside of the enclosure. (Failure to do so may void your warranty.) Then, line the enclosure with a polyester fiberfill blanket or fiberglass insulation about 1" thick.
9. Apply the included foam gasket to the speaker to ensure a sealed fit. Be sure that the mounting holes line up on the gasket.
10. Connect the wires to the woofer observing the proper polarity, positive and negative terminals. Strip away the insulation of the wire about a 1/4" and install the wires into the terminal posts.
11. Install the woofer into the enclosure using the 10-32 bolts (supplied).
12. Once the box is complete, it's time to connect the speaker wire coming from the subwoofer enclosure to your amplifier. Check that you use the proper wire for consistent polarity, positive and negative. (Refer to amplifier owner's manual.)
13. Finally, sit back and enjoy the incredible enhancement your new *PrecisionPower* subwoofer brings to your audio system.

BANDPASS ENCLOSURE

Bandpass speaker diagram

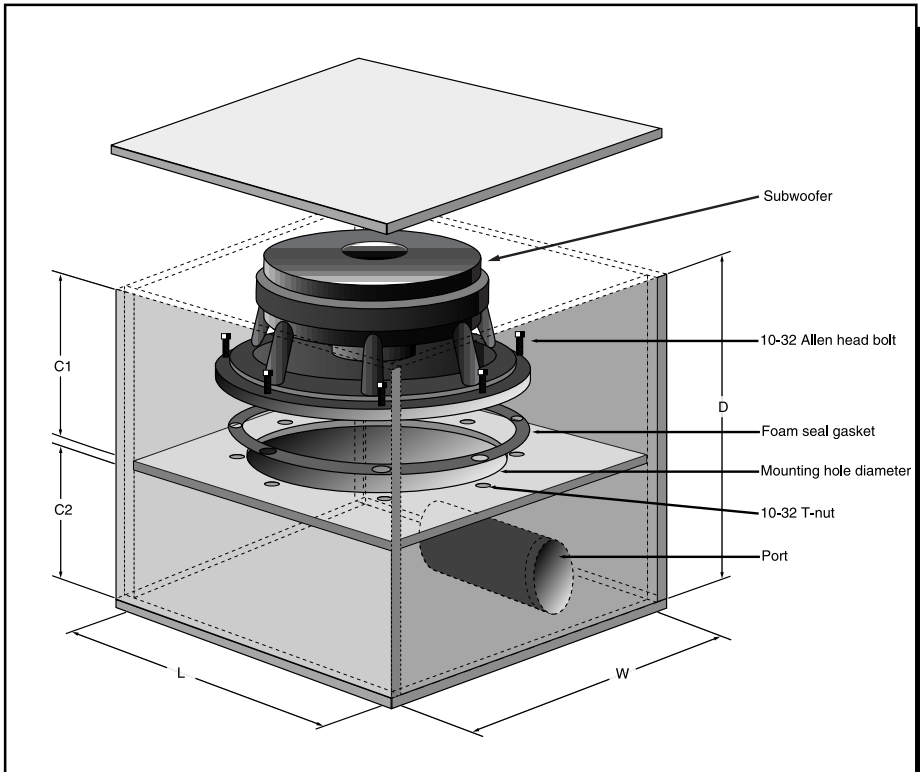

Internal dimensions should be calculated to determine the correct enclosure volume. Be sure to allow for speaker displacement, extra bracing (if used), and port displacement (only the length of the port that is INSIDE the enclosure). It may be necessary to angle the port to fit your design. To calculate the displacement of the port:

(Outside) $\text{Radius}^2 \times 3.14 \times \text{Length of the port that is inside the enclosure}$.

POWERCLASS PRO15 Subwoofer

Basic Working Dimensions for the PRO15

Outer Diameter	15.143"
Mounting Hole Diameter	13.75"
Mounting Depth (from bottom of top ring)	5.00"
Speaker Displacement	.21 cubic feet

PRO15 Sealed Enclosures

Net Volume	Internal Dimensions (see page 5)
1.5 cubic feet	18"L x 15"W x 10.75"D
2.50 cubic feet	23"L x 17"W x 11.75"D
3.5 cubic feet	24"L x 20"W x 14.00"D

PRO15 Ported Enclosures

Net Volume	Internal Dimensions (see page 7)
1.50 cubic feet	19"L x 16"W x 10"D
Port Tuned to 35Hz	6"Dia x 11.75" Long Port
1.75 cubic feet	20"L x 16"W x 10.75"D
Port Tuned to 45Hz	4"Dia x 6.125" Long Port
2.00 cubic feet	20"L x 16"W x 12"D
Port Tuned to 45Hz	6"Dia x 12.75" Long Port

PRO15 Bandpass Enclosures

	Net Volume	Internal Dimensions (see page 9)
Low Gain 31Hz to 148Hz	1.5 cu.ft. Sealed	15.5"L x 15.5"W x 12.25"C1
	.5 cu.ft. Ported	15.5"L x 15.5"W x 4.5"C2
	Port Tuned to 35Hz	2) 3"Dia x 10.25" Long Ports
Medium Gain 38Hz to 115Hz	1.5 cu.ft. Sealed	16.5"L x 16"W x 11"C1
	1.0 cu.ft. Ported	16.5"L x 16"W x 7.5"C2
	Port Tuned to 35Hz	2) 4"Dia x 8.5" Long Ports
High Gain 55Hz to 109Hz	1.0 cu.ft. Sealed	18"L x 16"W x 7.25"C1
	2.0 cu.ft. Ported	18"L x 16"W x 12"C2
	Port Tuned to 35Hz	1) 6"Dia x 1.75" Long Port

POWERCLASS PRO15 Subwoofer

PRO15 Sealed RESPONSE CURVE*

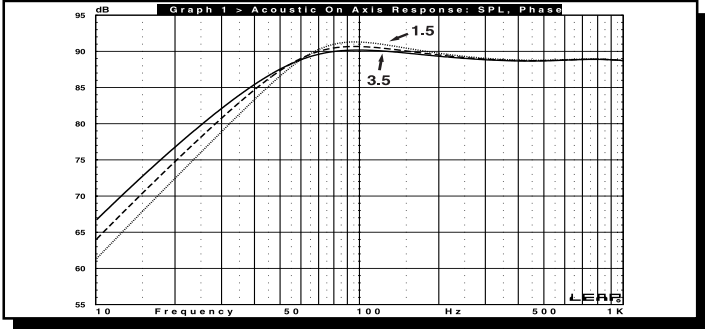

PRO15 Ported RESPONSE CURVE*

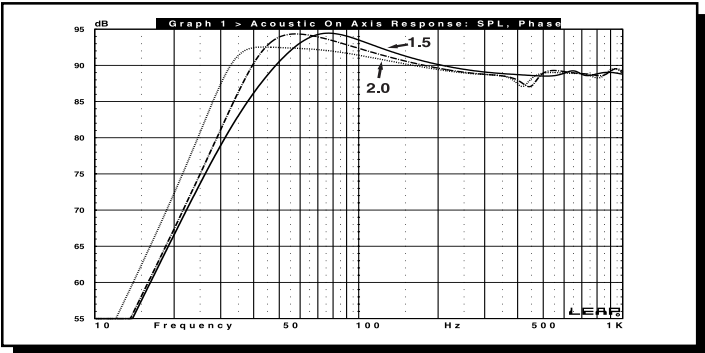

*ACTUAL IN-CAR RESPONSE CURVE WILL VARY BASED ON CAR TYPE, WOOFER LOADING, AND ENCLOSURE DESIGN.

PRO15 Bandpass RESPONSE CURVE*

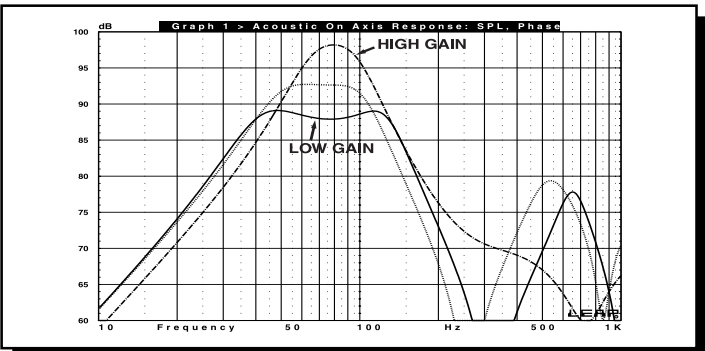

*ACTUAL IN-CAR RESPONSE CURVE WILL VARY BASED ON CAR TYPE, WOOFER LOADING, AND ENCLOSURE DESIGN.

Additional information



The **PowerClass PRO15** subwoofer will give you excellent results in enclosures from 1.5 cubic feet to over 3.5 cubic feet, ported or sealed.

Our dealers are trained to achieve the highest level of performance from our products. If you are installing your new subwoofers on your own and need assistance, please call your local **PrecisionPower** dealer or **PrecisionPower** Technical Service Department at

1-800-62-POWER.

Thanks again for choosing **PrecisionPower**.



 **FerroSound** The Solution Is Loud And Clear™

Ferrosound means more stable sound quality and performance, smoother frequency response, reduced distortion, increased power handling, greater efficiency and voice coil centering.

NOTE: Abuse and/or Installation Error: **PrecisionPower** defines abuse as, but not limited to, burnt voice coils (blackened, no continuity, melted adhesives, coil separated from the former, etc.), punctured or damaged surrounds, broken speaker terminals, non-**PrecisionPower** modifications, bent, chipped, or broken frames, ripped spiders, or damaged back plates. Speakers submitted with any of the above will be considered out of warranty.

WARRANTY

Three-Year Limited U.S.A. Warranty

This warranty gives you specific legal rights, and you may also have other rights which vary from state to state. **PrecisionPower** warrants its products to be free from defects in materials and workmanship under normal use and service for a period of three (3) years from the date of original purchase when the unit is installed by an Authorized Dealer. Non-Authorized Dealer installed products carry a one (1) year parts and ninety (90) days labor limited warranty. The extent and conditions of Limited Warranty are as follows:

1. Authorized Dealer Installed Products: **PrecisionPower** will either repair or replace at no charge, to the original purchaser, any unit which **PrecisionPower's** examination discloses to be defective and under warranty, provided the defect occurs within three (3) years from the date of original purchase when the unit is installed by an Authorized Dealer and the product is returned immediately to **PrecisionPower**. This warranty is not transferable.

2. Non-Authorized Dealer Installed Products: **PrecisionPower** will either repair or replace at no charge, to the original purchaser, any unit which **PrecisionPower's** examination discloses to be defective and under warranty, provided the defect occurs within ninety (90) days from the date of purchase and the product is returned immediately to **PrecisionPower**. Warranty claims beyond ninety (90) days for Non-Authorized Dealer Installed Products will be for parts only and will extend for one (1) year from the date of purchase. This warranty is not transferable.

3. The date of purchase and proof of Authorized Dealer Installation of a PrecisionPower product must be established by an original sales receipt which must accompany the article being returned for warranty work.

4. This warranty shall NOT apply to any **PrecisionPower** product found to have the original factory serial number removed or defaced. All products received (by **PrecisionPower**) for in-warranty or out of warranty repair, with their original serial numbers removed or defaced, will NOT be repaired and will be returned to sender, freight collect. Refer to original packaging for the serial number of your component speakers.

5. The provisions of this warranty shall not apply to any **PrecisionPower** product used for a purpose for which it is not designed, which has been repaired or altered in any way, or which has been connected, installed, or adjusted other than in accordance with the instructions furnished in **PrecisionPower's** owner's manual. Nor shall this warranty apply to any part which has been subject to misuse, neglect, or accident.

6. PrecisionPower does not authorize any other persons to assume any other liability in connection with its products. THIS WARRANTY IS THE ONLY EXPRESS WARRANTY MADE BY PRECISIONPOWER APPLICABLE TO ITS PRODUCTS. ANY IMPLIED WARRANTY OR MERCHANTABILITY OR FITNESS FOR A PARTICULAR PURPOSE APPLICABLE TO PRECISIONPOWER PRODUCTS IS LIMITED IN DURATION TO THE DURATION OF THIS LIMITED WARRANTY. PRECISIONPOWER SHALL NOT BE LIABLE FOR THE INCIDENTAL, CONSEQUENTIAL, OR COMMERCIAL DAMAGES RESULTING FROM THE BREACH OF THIS WRITTEN WARRANTY. Some states or provinces do not allow the exclusion or limitation of incidental or consequential damages or limitations on how long an implied warranty lasts; so the above limitations or exclusions may not apply to you.

7. Your product will be serviced on an in-warranty basis within the warranty period for the correction of warranted defects. If improper operation of your **PrecisionPower** product should occur, contact your Authorized Dealer for assistance with the return and factory repair of your **PrecisionPower** product. If an Authorized Dealer is not available, return the unit including your name, telephone number, return address, a copy of your sales receipt, and a description of the problem to:

PrecisionPower, Inc.
Service Department
4829 S. 38th Street
Phoenix, AZ 85040-2964

TO RETURN PRECISIONPOWER PRODUCTS OUT OF WARRANTY: Return the unit, postage prepaid, in the original protective carton. Please include a description of the problem and, if desired, a request for an estimate of repair costs. Unless a request for an estimate is included, the unit will be repaired as necessary. Please contact **PrecisionPower** Customer Service at 1-800-62-POWER for questions concerning out of warranty repair charges. Repaired unit will be returned with an itemized statement, C.O.D.

RETURN TO CONTENTS